

Single Position Meter Test Bench

Calmet TB10

- New generation of the fully automated Smart Meter Test Bench
- Accuracy class 0.02% or 0.05% with internal reference meter
- Extremely high accuracy class with external reference meter
- Automatic Test Procedures
- Three-phase current and voltage source
- Programmed form and special shapes of currents and voltages
- Current and Voltage source in range 0.001A...120A and 0.5...560V
- Testing of meters with closed I-P links
- Signal generation without auxiliary amplifiers
- Compact design size and light weight
- AC single phase power supply operation only
- Calibration Certificate

The Calmet TB10 Single Position Desktop Meter Test Bench is used for calibration and testing of single and three phase electromechanical and electronic active and reactive electricity meters and portable test equipment with accuracy referenced to an internal reference meter.



The Calmet TB10 Test Bench employs modern precision power source with the internal reference (without need to use an additional external reference energy meter with additional cables). By this conception may be achieved simultaneously flexible customer orientated solution characterised by extremely compact size, light weight, high metrological properties at reasonable price.

In case the high-accuracy application requirement, it is possible to upgrade the existing Calmet TB10 Test Bench by adding an external reference meter.

The Calmet TB10 Test Bench comprises:

- three phase power source with accuracy class of internal reference 0.02 or 0.05. Three phase power source generates voltage up to 560V and current up to 120A with programmable shapes, frequency in 40...500Hz range and phase shifts in $0...±360°$ range,
- single position testing stand with photo scanning head and cables,
- Calpro 300 Basic + TS (Test System) software.

The Calmet TB10 Test Bench performs the following automatic tests of electricity meters:

- measure the basic error characteristics and repeatability,
- checking the starting current,
- checking the no-load run,
- measure the influence of frequency, voltage, self-heating, reversed phase sequence, distortion and special shapes of currents and voltages,
- checking the impulse output and energy meter counter,
- checking the maximum power indicator.

Configuration of the Calmet TB10 with using external Reference meter

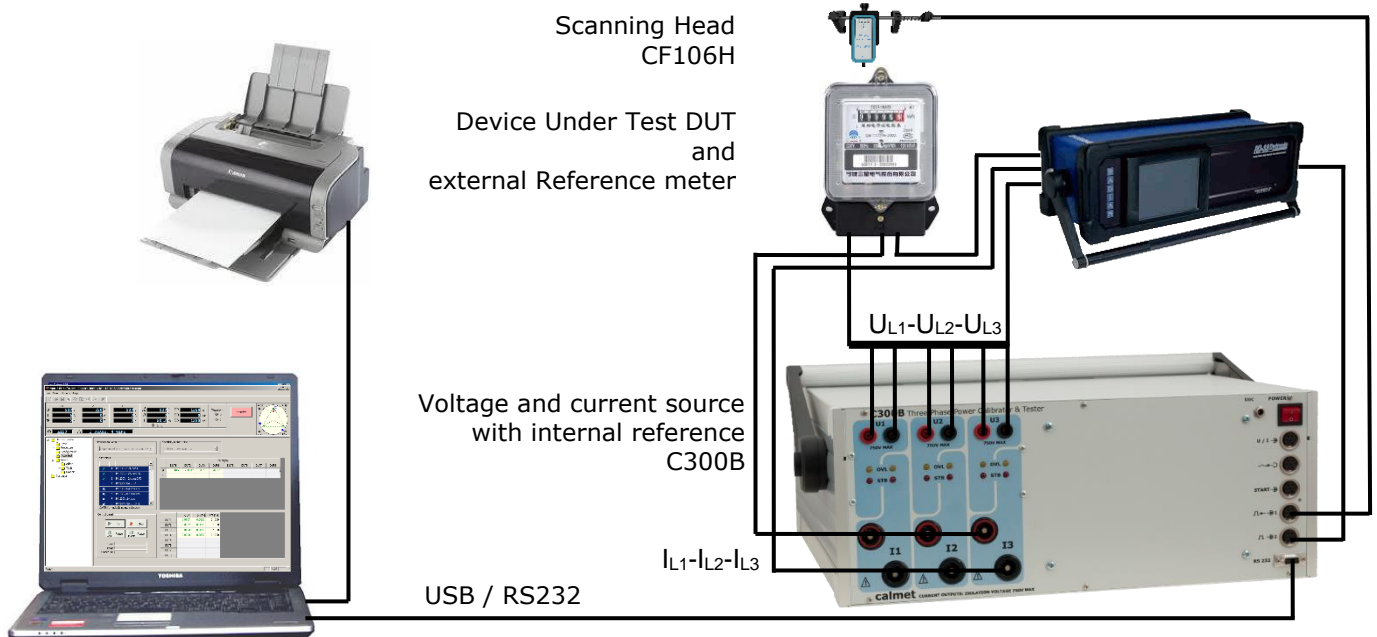

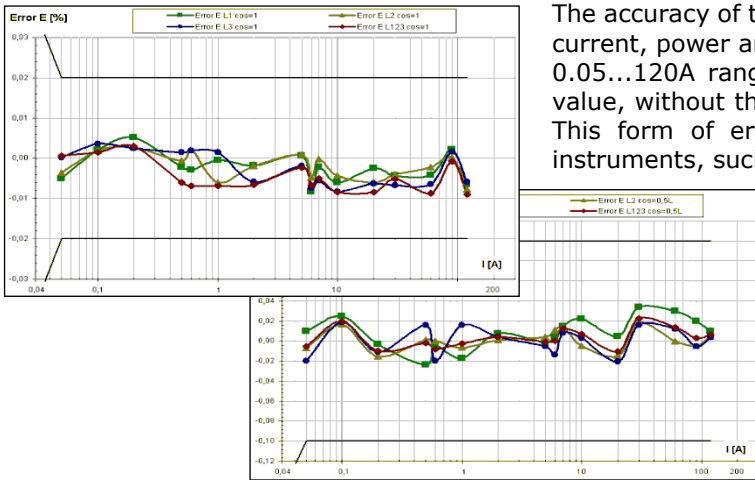

The accuracy of the basic parameters of the Calmet TB10 - voltage, current, power and energy in a wide voltage 21...560V and current 0.05...120A ranges, is expressed as a percentage of the setting value, without the component as a percentage of the range value. This form of errors specification is very useful when checking instruments, such as electricity meters.

Energy errors diagrams of the Calmet TB10 class 0.02 as a function of current settings for balanced and unbalanced loads at 230V/50Hz and power factor $\cos\varphi=1$ and 0.5L, achieved in automatic test procedure using Calpro300 TS software and reference meter Radian RD33.

| Power source with internal reference | | | | Uncertainty ¹⁾ | | Maximum load |
|--------------------------------------|-----------|---|-----------------------|---------------------------|-------------------------|---|
| Parameter | Range | Settings span | Resolution | class 0.02 | class 0.05 | |
| Voltage U | 70V | 0.5000...70.0000V | 0.0001V | ±0.02% ²⁾⁴⁾ | ±0.05% ²⁾⁴⁾ | 560mA@70V |
| | 140V | 1.000...140.000V | 0.001V | | | 280mA@140V |
| | 280V | 2.000...280.000V | 0.001V | | | 140mA@280V |
| | 560V | 5.000...560.000V | 0.001V | | | 70mA@560V |
| Voltage short term [1h] stability | | | | ±0.005% ²⁾ | ±0.010% ²⁾ | |
| Voltage long term [1year] stability | | | | ±0.01% ²⁾ | ±0.02% ²⁾ | |
| Voltage temperature drift per 1°C | | | | ±0.0005% ²⁾ | ±0.0010% ²⁾ | |
| Voltage distortion factor | | | | < 0.1% | | |
| Current I | 0.5A | 0.001000...0.500000A | 0.000001A | ±0.02% ²⁾⁵⁾ | ±0.05% ²⁾⁵⁾ | 17V@0.5A |
| | 6A | 0.05000...6.00000A | 0.00001A | | | 8.5V@6A |
| | 20A | 0.2000...20.0000A | 0.0001A | | | 3.3V@20A |
| | 120A | 1.000...120.000A | 0.001A | | | 0.95V@60A ⁷⁾ 0.70V@120A ⁷⁾ |
| Current short term [1h] stability | | | | ±0.005% ²⁾ | ±0.010% ²⁾ | |
| Current long term [1year] stability | | | | ±0.01% ²⁾ | ±0.02% ²⁾ | |
| Current temperature drift per 1°C | | | | ±0.0005% ²⁾ | ±0.0010% ²⁾ | |
| Current distortion factor | | | | < 0.1% | | |
| Frequency f | | 40.000...500.000Hz | 0.001Hz | ±0.005% | | |
| Phase shift φ | | 0.00...±360.00° | 0.01° | ±0.05° ²⁾ | ±0.10° ²⁾ | |
| Active power P | | 0...3x67200.0W | 0.00001-0.1W | ±0.02% ²⁾³⁾ | ±0.05% ²⁾³⁾ | |
| Reactive power Q | | 0...3x67200.0var | 0.00001-0.1var | ±0.02% ²⁾³⁾ | ±0.05% ²⁾³⁾ | |
| Apparent power S | | 0...3x67200.0VA | 0.00001-0.1VA | ±0.02% ²⁾ | ±0.05% ²⁾ | |
| Power short term [1h] stability | | | | ±0.005% ²⁾⁸⁾ | ±0.010% ²⁾⁸⁾ | |
| Power long term [1year] stability | | | | ±0.01% ²⁾⁸⁾ | ±0.02% ²⁾⁸⁾ | |
| Power temperature drift per 1°C | | | | ±0.0005% ²⁾ | ±0.0010% ²⁾ | |
| Harmonics | magnitude | up to 64 th or 3200Hz | 0...100% output value | ±0.02% ⁹⁾ | | |
| | phase | | 0...360° | ±0.5° ⁹⁾ | | |
| Time ⁶⁾ | | 1...36000s | 1s | ±0.01% ±0.001s | | |
| Energy | | calculated from settings of power and time | | ±0.02% ²⁾³⁾ | ±0.05% ²⁾³⁾ | |
| Impulse input | | two impulse inputs: IN _L 0...2V, IN _H 4...27V up to 200kHz (150kHz with external reference meter) | | | | |
| Impulse output | | programmable impulse output: open collector 28V/100mA up to 210kHz | | | | |
| Special shapes | | Phase Fired and Burst acc. To EN50470 | | | | |
| Power supply | | Single phase 90V...264V / 47...63Hz / 900VA acc. to IEC 60359 for group I | | | | |
| Dimensions and weight | | (width 480 x height 200 x depth 560)mm and 28kg | | | | |

| Testing stand | |
|---------------|---|
| Test rack | Single position test rack is made of light aluminium profiles Dimensions (width 760 x height 340 x depth 380)mm and weight 4kg |
| Set of cables | Set of safety voltage cables (4 units), set of safety current cables up to 20A (6 units) and up to 120A (6 units) with set of accessories for safety cables |

Photo scanning head
Photo scanning head type CF106H (1unit) which detects the disc movement or the LED flash of the meter

- 1) absolute extended uncertainty under confidence level of 95% covers reference uncertainty of standards, stability in 12 months, influence quantities (ambient temperature in range +20...+26°C, humidity and power supply voltage according to the table 2.3, load acc. to table 2.1, frequency in range 45...65Hz) and nonlinearity. For frequency band below 45Hz and above 65Hz - linear rise up typically to double value for frequency 40Hz and 500Hz
- 2) of setting value, for settings from 10% of current range and 30% of voltage range
- 3) uncertainty of power P(Q) under $\cos\varphi(\sin\varphi)=1$, for $\cos\varphi(\sin\varphi)\neq 1$ linear rise up to 0.15% (class 0.02) or 0.30% (class 0.05) for $\cos\varphi(\sin\varphi)=0.5$
- 4) for voltage below 30% of range uncertainty 0.006% of range (class 0.02) or 0.015% of range (class 0.05)
- 5) for current below 10% of range uncertainty 0.002% of range (class 0.02) or 0.005% of range (class 0.05)
- 6) for energy dosage
- 7) 0.85V@60A and 0.50V@120A using the AKD300 current cables length 1m
- 8) stability of power S and P(Q) under $\cos\varphi(\sin\varphi)=1$, for $\cos\varphi(\sin\varphi)\neq 1$ linear rise up to 0.04% for $\cos\varphi(\sin\varphi)=0.5$
- 9) 0,02% of output value and 0,5° for frequency range of harmonics 80-120Hz with linear rise up to 0.2% of output value and 4° for 3200Hz

The Calmet TB10 Test Bench is controlled by means of personal computer with installed Calpro 300 software in MS Windows operating system.

Calpro 300 features:

- using a modern concept, which allows the operator to create own test procedures - this is very important because new requirements for new meter generations can be realized easily without changing the complete software,
- the automated mode - direct execution of the complete test procedure automatically and requires no more additional handling by operator unless it will not be defined in the test procedure,
- the manual mode - direct execution of single test step. It offers an ideal solution for tests and evaluation of entire specifications for devices under test without generating the complete test procedure,
- computer database of customers, devices, measurement procedures as well as edition of results, diagrams, tables of results and reports,
- export of results to MS Excel,
- traditional manual settings the value of all parameters of output signals.

Advantages of Calpro 300 PC soft:

- user-friendly operation,
- database for meters and test procedures,
- fully-automatic test procedures,
- continuous monitoring of the test,
- tables and graphics for presentation of results,
- operator interface available in several languages,
- automatic measurements report generation.

Calpro 300 Basic software version enables traditional manual setting:

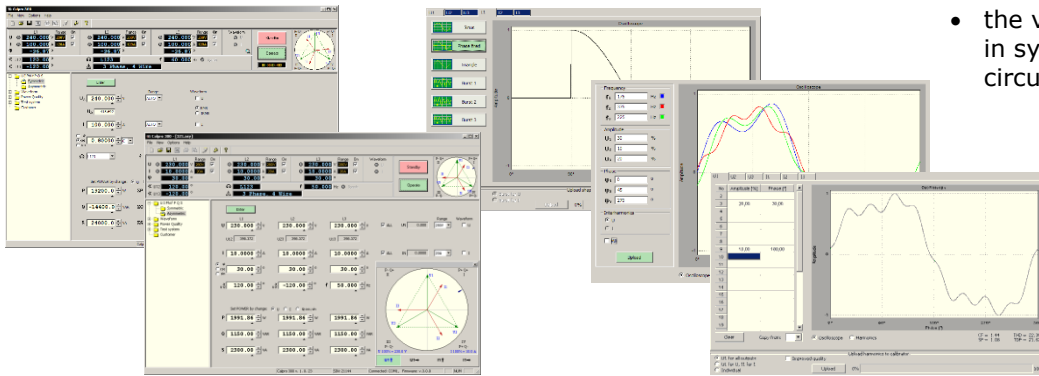

- the value of $U+I+\phi+f+P+Q+S$ in symmetric and asymmetric circuit of connection,
- the wave shape of voltage and current with using harmonics, interharmonics and shape functions.

Calpro 300 TS Test System software version enables using a modern concept, which allows the operator to create own test procedures with using automated / manual mode for automatic testing the following devices:

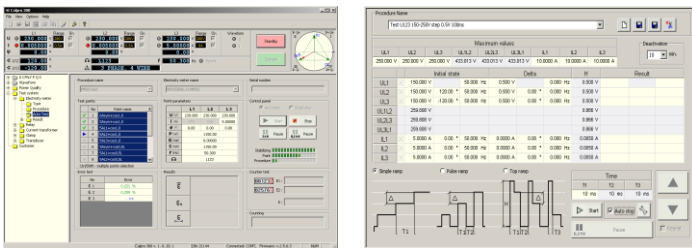

- electricity meters (error, repeatability, counting and counter & constant),
- current clamps,
- current transformers,
- measurement transducers,
- protection relays (*Quick* function for quick relay's testing, *Trigger Time* function for tripping time testing and *Trigger Level* function for tripping level testing).

Calpro 300 PQ Power Quality software version enables generating sinusoidal and nonsinusoidal voltage and current, which value is changed in time for testing meters, recorders and power quality analyzers with the following functions:

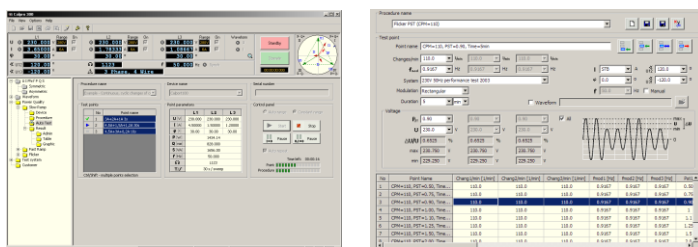

- *Slow Ramp* for generate voltage and current which value is changed relative slow to the time,
- *Fast Ramp* for generate voltage and current which value is changed relative fast to the time,
- *Flicker* for generate voltage fluctuation (Flicker) levels expressed in Plt and Pst coefficients.

The Calmet TB10 Meter Test Bench's set

Calpro 300 Basic + TS + PQ have the following functions:

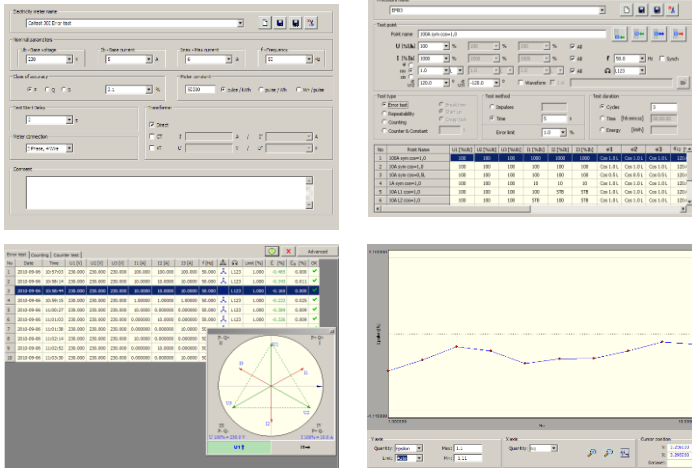

- *Type* for entering data to testing devices database,
- *Procedure* for entering data to measuring procedures database,
- *Auto Test* for performing automatic test of device,
- *Result* for visualization, *edition* and storing measurements results in form of tables and diagrams, easy Report generation, printing and exporting data to MS Excel,
- *Customer function* for collecting data in customer database and *Admin* function for using customer database during reports edition.

| Calmet TB10 | | | |
|--|--|---|--|
| All completed Calmet TB10 Test Bench's set consists of: | | | |
| <ul style="list-style-type: none"> • C300B calibrator case class 0.02 or 0.05, • Calpro 300 Basic + TS software – for automatic test of electric equipment, • ER10 single position rack for hanging of meter under test • CF106H photo head with holder for inductive meter and meter with LED, • EA32 set of safety voltage cables (4units) and current cables up to 20A (6units), • set of accessories for safety cables (12units banana plug +12units Cu), • AKD300 current cables up to 120A (6units) with set (18units) of replaceable terminals • AD300 sockets adapter, • power cord, • USB / RS232 adapter, • fuse T4A, 250V, 5x20 (2units), • C091A T3475-001 plug Amphenol for Calibrator inputs, • operation manual of calibrator and software (3units), • warranty card, • calibration certificate. | | | |
| Optionally for Calmet TB10 Test Bench are available: | | | |
| <ul style="list-style-type: none"> • EH10.3 quick connection device, | | <ul style="list-style-type: none"> • Calpro 300PQ PC Soft for Power Quality measurement devices testing, | |
| <ul style="list-style-type: none"> • External reference meter Radian Research | | <ul style="list-style-type: none"> • Computer Laptop PC with Calpro300 PC Soft, | |
| <ul style="list-style-type: none"> • RS232 – Bluetooth adapter for wireless connection, | | <ul style="list-style-type: none"> • C091A T3475-001 plug Amphenol for Calibrator inputs. | |
| <ul style="list-style-type: none"> • CF106H miniature photo head for inductive meters, | | <ul style="list-style-type: none"> • UCF100 holder for CF100 and CF101 photo heads, | |
| <ul style="list-style-type: none"> • CF100 miniature photo head for meters with LED, | | | |

Calmet sp. z o.o.

Kukulcza 18, 65-472 Zielona Gora, Poland

Phone +48 68 324 04 56 Fax +48 68 324 04 57

E-mail: mail@calmet.com.pl Web access: <http://www.calmet.com.pl>